

Baugröße - Size - Modèle: G 6.1

Type	50/60 Hz		Leistungsaufnahme Power consumption Puissance absorbée	Nennstrom bei 400V Rated current at 400V Courant nominal à 400V	Leistungsfaktor Power factor Facteur de puissance	Anlaufstrom / Nennstrom Starting current / Rated c. C. de démarr. / C. nomin.	Bohrbild Drilling pattern Plan de perçage			Fußmaße Mounting dimensions Dimensions pied			Motormaße Motor dimensions Dimensions moteur				Gewicht Weight Poids
	Arbeitsmoment Working torque Couple de service [kgcm]	Fliehkraft Centrifugal force Force centrifuge [kN]					R	S	Ø	L	M	N	X	Y	Z	T	
8-polig-50/60 Hz-730/880 min⁻¹																	
G61-800-8	800/552	23,36	3,13	7,20	0,66	5,90	105	280	26	370	370	30	780	390	415	200	263
G61-900-8	900/621	26,28	3,13	7,20	0,66	5,90	105	280	26	370	370	30	780	390	415	200	273
G61-1000-8	1000/690	29,20	3,13	7,20	0,66	5,90	105	280	26	370	370	30	680	390	415	200	278
G61-1300-8	1300/897	37,96	3,13	7,20	0,66	5,90	105	280	26	370	370	30	780	390	415	200	293
G61-1550-8	1550/1070	45,26	3,13	7,20	0,66	5,90	105	280	26	370	370	30	780	390	415	200	318
6-polig-50/60 Hz-980/1176 min⁻¹																	
G61-700-6	700/483	36,05	4,80	8,70	0,84	6,80	105	280	26	370	370	30	780	390	415	200	263
G61-800-6	800/552	41,20	4,80	8,70	0,84	6,80	105	280	26	370	370	30	780	390	415	200	268
G61-900-6	900/621	46,35	4,80	8,70	0,84	6,80	105	280	26	370	370	30	780	390	415	200	273
G61-1000-6	1000/690	51,50	4,80	8,70	0,84	6,80	105	280	26	370	370	30	680	390	415	200	278
G61-1300-6	1300/897	66,95	4,80	8,70	0,84	6,80	105	280	26	370	370	30	780	390	415	200	293
4-polig-50/60 Hz-1460/1750 min⁻¹																	
G61-400-4	400/276	46,72	4,72	7,60	0,90	6,20	105	280	26	370	370	30	680	390	415	200	243
G61-500-4	500/345	58,40	4,72	7,60	0,90	6,20	105	280	26	370	370	30	680	390	415	200	248

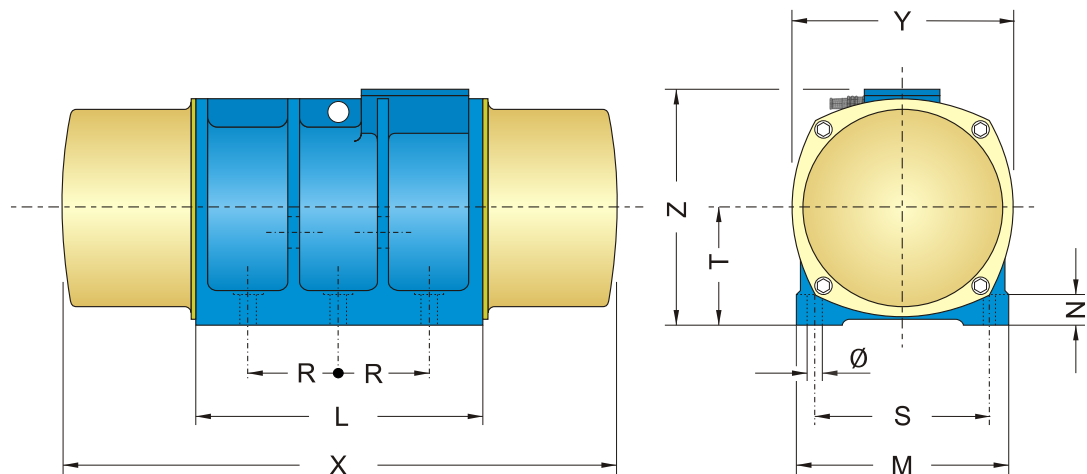

Baugröße - Size - Modèle: GE 6.1

Type	50/60 Hz		Leistungsaufnahme Power consumption Puissance absorbée	Nennstrom bei 400V Rated current at 400V Courant nominal à 400V	Leistungsfaktor Power factor Facteur de puissance	Anlaufstrom / Nennstrom Starting current / Rated c. C. de démarr. / C. nomin.	Bohrbild Drilling pattern Plan de perçage			Fußmaße Mounting dimensions Dimensions pied			Motormaße Motor dimensions Dimensions moteur				Gewicht Weight Poids
	Arbeitsmoment Working torque Couple de service [kgcm]	Fliehkraft Centrifugal force Force centrifuge [kN]					R	S	Ø	L	M	N	X	Y	Z	T	
8-polig-50/60 Hz-730/880 min⁻¹																	
GE61-1550-8	1550/1070	45,26	3,13	7,20	0,66	5,90	105	280	26	370	370	30	780	390	415	200	316
GE61-1750-8	1750/1208	51,10	3,13	7,20	0,66	5,90	105	280	26	370	370	30	880	390	415	200	328
6-polig-50/60 Hz-980/1176 min⁻¹																	
GE61-1000-6	1000/690	51,50	4,80	8,70	0,84	6,80	105	280	26	370	370	30	680	390	415	200	289
GE61-1300-6	1300/897	66,95	4,80	8,70	0,84	6,80	105	280	26	370	370	30	780	390	415	200	304
GE61-1550-6	1550/1070	90,13	4,80	8,70	0,84	6,80	105	280	26	370	370	30	780	390	415	200	316