

Baugröße - Size - Modèle: G 5.0

Type	50/60 Hz	Fliehkraft Centrifugal force Force centrifuge	Leistungsaufnahme Power consumption Puissance absorbée	Nennstrom bei 400V Rated current at 400V Courant nominal à 400V	Leistungsfaktor Power factor Facteur de puissance	Anlaufstrom / Nennstrom Starting current / Rated c. C. de démarr. / C. nomin.	Bohrbild Drilling pattern Plan de perçage			Fußmaße Mounting dimensions Dimensions pied			Motormaße Motor dimensions Dimensions moteur				Gewicht Weight Poids
	[kgcm]						[kN]	[KW]	[A]	cos	IN/IA	R Länge Longueur [mm]	S Breite Width Largeur [mm]	Ø Durchmesser Diameter Diamètre [mm]	L Länge Length Longueur [mm]	M Breite Width Largeur [mm]	
8-polig-50/60 Hz-730/880 min⁻¹																	
G50-500-8	500/345	14,60	2,27	4,40	0,75	6,50	105	248	26	320	340	24	640	340	370	175	174
G50-600-8	600/414	17,52	2,27	4,40	0,75	6,50	105	248	26	320	340	24	640	340	370	175	182
G50-700-8	700/483	20,44	2,27	4,40	0,75	6,50	105	248	26	320	340	24	640	340	370	175	190
G50-800-8	800/552	23,36	2,27	4,40	0,75	6,50	105	248	26	320	340	24	730	340	370	175	198
6-polig-50/60 Hz-980/1176 min⁻¹																	
G50-500-6	500/345	25,75	3,60	6,70	0,77	6,10	105	248	26	320	340	24	640	340	370	175	174
G50-600-6	600/414	30,90	3,60	6,70	0,77	6,10	105	248	26	320	340	24	640	340	370	175	182
G50-700-6	700/483	36,05	3,60	6,70	0,77	6,10	105	248	26	320	340	24	640	340	370	175	190
4-polig-50/60 Hz-1460/1750 min⁻¹																	
G50-300-4	300/207	35,04	3,37	6,10	0,88	5,80	105	248	26	320	340	24	640	340	370	175	158
G50-350-4	350/242	40,88	3,37	6,10	0,88	5,80	105	248	26	320	340	24	730	340	370	175	162

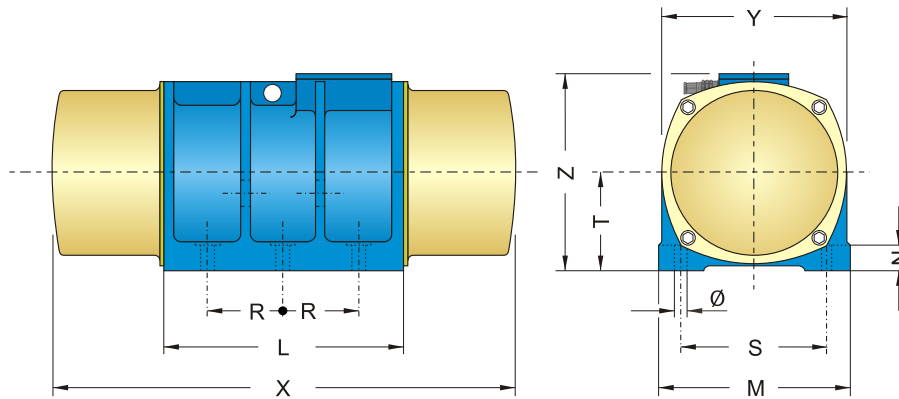

Baugröße - Size - Modèle: GE 5.0

Type	50/60 Hz	Fliehkraft Centrifugal force Force centrifuge	Leistungsaufnahme Power consumption Puissance absorbée	Nennstrom bei 400V Rated current at 400V Courant nominal à 400V	Leistungsfaktor Power factor Facteur de puissance	Anlaufstrom / Nennstrom Starting current / Rated c. C. de démarr. / C. nomin.	Bohrbild Drilling pattern Plan de perçage			Fußmaße Mounting dimensions Dimensions pied			Motormaße Motor dimensions Dimensions moteur				Gewicht Weight Poids
	[kgcm]						[kN]	[KW]	[A]	cos	IN/IA	R Länge Longueur [mm]	S Breite Width Largeur [mm]	Ø Durchmesser Diameter Diamètre [mm]	L Länge Length Longueur [mm]	M Breite Width Largeur [mm]	
8-polig-50/60 Hz-730/880min⁻¹																	
GE50-800-8	800/552	23,36	3,13	5,90	0,77	7,80	105	248	26	320	340	24	730	340	370	175	208
GE50-1000-8	1000/690	29,20	3,13	5,90	0,77	7,80	105	248	26	320	340	24	730	340	370	175	224
6-polig-50/60 Hz-980/1176 min⁻¹																	
GE50-600-6	600/414	30,90	4,80	8,70	0,80	6,80	105	248	26	320	340	24	640	340	370	175	192
GE50-700-6	700/483	36,05	4,80	8,70	0,80	6,80	105	248	26	320	340	24	640	340	370	175	200
GE50-800-6	800/552	41,20	4,80	8,70	0,80	6,80	105	248	26	320	340	24	730	340	370	175	208
GE50-900-6	900/621	46,35	4,80	8,70	0,80	6,80	105	248	26	320	340	24	730	340	370	175	216
4-polig-50/60 Hz-1460/1750 min⁻¹																	
GE50-300-4	300/207	35,04	4,70	7,50	0,90	6,10	105	248	26	320	340	24	640	340	370	175	168
GE50-350-4	350/242	40,88	4,70	7,50	0,90	6,10	105	248	26	320	340	24	730	340	370	175	172
GE50-400-4	400/276	46,72	4,70	7,50	0,90	6,10	105	248	26	320	340	24	575	340	370	175	176
2-polig-50/60 Hz-2850/3420 min⁻¹																	
GE50-90-2	90/62	39,76	5,00	7,80	0,92	8,40	105	248	26	320	340	24	575	340	370	175	162
GE50-125-2	125/86	55,23	5,00	7,80	0,92	8,40	105	248	26	320	340	24	575	340	370	175	167